

Price index



Low noise version E4/101
Series 221 available with
special rubber pads design



Cleanroom test
upon request



ESD classification:
Electrically conductive ESD/ATEX
version upon request



Opening e-chains®: Remove crossbars and
clips - Insert screwdriver into the slot, push
down, release by lever action



Remove lids/bottoms (e-tubes) - Insert screw-
driver into the slot, release by lever action



When to use the Series 220/R760:

- If a low-noise version is required
- At very high speeds and/or accelerations
- For long travels
- For high additional loads



When not to use it:

- Zig-zag lift applications
 - ▶ System E4/4, from page 7.312
- For side-mounted applications
 - ▶ System E4/4, from page 7.312
- If an extrem vibration-free e-chain® is necessary
 - ▶ Series E6.29/R6.29, page 8.40/8.46

- ❶ Crossbars are removable along both radii
- ❷ Wide, rounded plastic crossbars - cable friendly
- ❸ Stop dog with "brake" for noise reduction
- ❹ Closed and open styles can be combined
- ❺ Hinged snap-open removable lids
along outer radius of e-tube
- ❻ Optimized glide pads
- ❼ Numerous interior separation possibilities
- ❽ KMA mounting brackets with
attachment points on all sides
- ❾ Locking or pivoting mounting brackets available
- ❿ Integrated strain relief possible
- ⓫ e-chains® also available with
reverse bending radius "RBR"

Also available as
E4/00-NC without
camber: 220-NC



Order example complete e-chain®

Please indicate chain-lengths or number of links Example: 3 m or 66 links

3 m 220.300.250.0

e-chain®

with 2 separators 2211 assembled every 2nd link

Interior separation

1 set 2200.300.1.12

Mounting bracket



Unsupported length

FL_G = with straight upper run
 FL_B = with permitted sag
 Further information ► Design, page 1.12

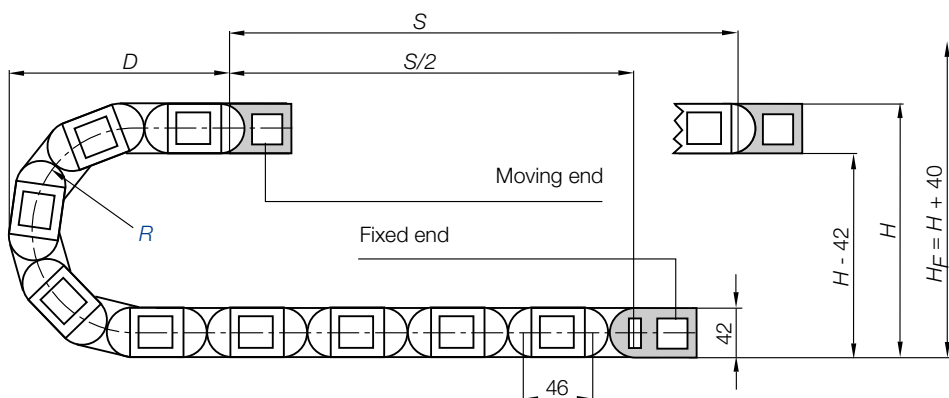
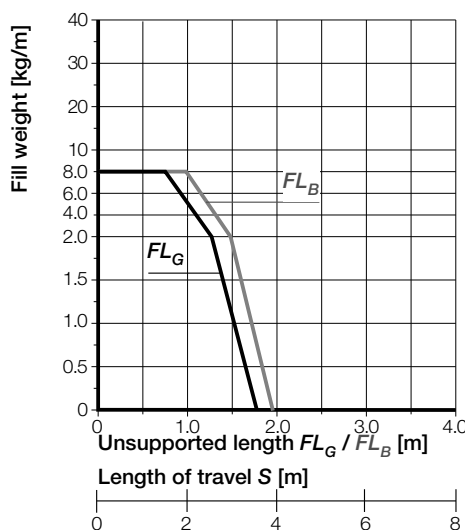
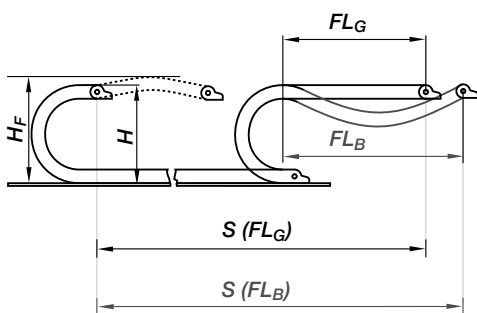

Pitch = 46 mm/link Links/m = 22 (1012 mm) Chain length = $S/2 + K$

R	055*	063*	075	100	125	150	175	200	250
H	154	170	194	244	294	344	394	444	544
D	125	133	145	170	195	220	245	270	320
K	265	290	330	410	485	565	645	725	880
H ₂	112	128	152	158	158	158	158	158	158
D ₂ ⁺²⁵	125	133	145	350	490	530	655	730	935
K ₂	265	290	330	598	782	920	1104	1242	1610

*not available for R760

- S = Length of travel
- R = Bending radius
- H = Nominal clearance height
- H_F = Required clearance height
- H_{RI} = Trough inner height
- D = Overlength e-chain*
radius in final position
- K = $\pi \cdot R$ + "safety"
- D₂ = Over length - long travels, gliding
- K₂ = *Further add-on
- H₂ = *Mounting height
- *if the mounting bracket location is set lower

Other installation methods

- Vertical, hanging ≤ 80 m
- Vertical, standing ≤ 5 m
- Side mounted, unsp. ≤ 2 m
- Rotary requires further calculation
- Unsupported length of upper run = upon request



Short travels - unsupported

Unsupported e-chains® feature positive camber over short travels. This must be accounted for when specifying the clearance height H_F. Please consult igus® if space is particularly restricted.

The required clearance height:
H_F = H + 40 mm
 (with 1,0 kg/m fill weight)

Long travel lengths from 10 m to max. 200 m Chain length = $S/2 + K_2$

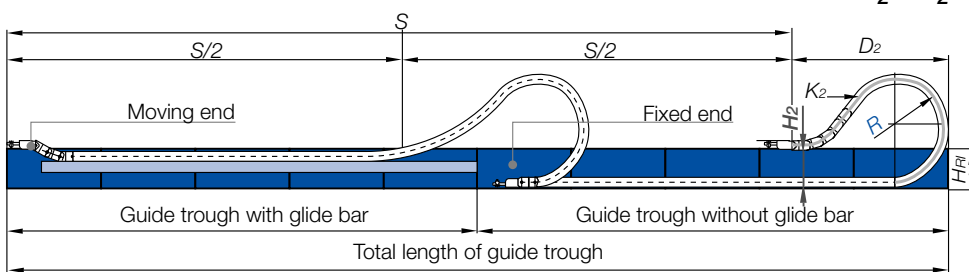

In case of travels between 4 and 10 m we recommend a longer unsupported length.



Gliding, long travel applications (max. 200 m)

In this case the e-chain® upper run will be introduced in a guide trough on the lower run. We recommend to realize the engineering of such a plant by our technicians.

Technical Data

Speed / acceleration FL_G	max. 20 [m/s] / max. 200 [m/s ²]
Speed / acceleration FL_B	max. 3 [m/s] / max. 6 [m/s ²]
Gliding speed / acceleration (maximum)	max. 10 [m/s] / max. 50 [m/s ²]
Material - permitted temperature °C	igumid G / -40° up to +120° C
Flammability class, igumid G	VDE 0304 IIC UL94 HB



Details of material properties

► page 1.38

For support of the lower run - Support Tray tool kit available ► page 9.70

System E4/00
Inner height: 28 mm

Phone +49- (0) 22 03-96 49-800
Fax +49- (0) 22 03-96 49-222



► page 7.255

igus® e-chainsystems®

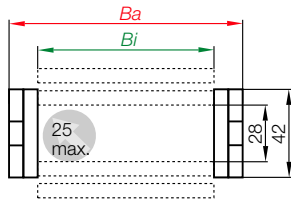

Part No. structure

220.	300.	250.	0
------	------	------	---



Series 220 - e-chain® with crossbars every link

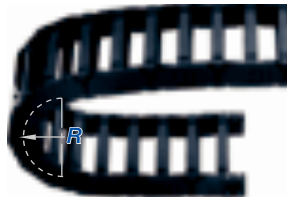

- Robust solution with crossbars every link
- Can be opened from two sides
- Removable crossbars



Phone +49- (0) 22 03-96 49-800
Fax +49- (0) 22 03-96 49-222

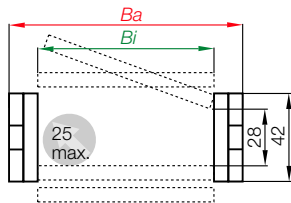

Part No. structure

760.	300.	250.	0
------	------	------	---



Series R760 - Fully enclosed e-tube



- Fully enclosed
- Excellent cable protection against dirt
- Protection against hot chips (up to 900°C)
- Lids along the entire inner radius are completely removable. Lids along the entire outer radius are single sided snap-open with a hinge on the other side to keep them attached to the chain or completely removable.



igus® GmbH
51147 Cologne

Low-noise! Special low-noise version with rubber pads

Series 221 - Order example 221.100.250.0

Further information:

www.igus.de or phone +49-(0) 22 03-96 49-800

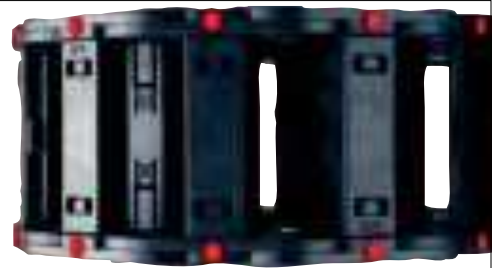

Internet: www.igus.eu
E-mail: info@igus.de

Part No.	<i>Bi</i> [mm]	<i>Ba</i> [mm]	220 [kg/m]	R760 [kg/m]
220.040..... <input type="text"/> .0	40	60	≈ 1,06	–
220/760.050.. <input type="text"/> .0	50	70	≈ 1,10	≈ 1,25
220.062..... <input type="text"/> .0	62	82	≈ 1,14	–
220.070..... <input type="text"/> .0	70	90	≈ 1,18	–
220./760.075.. <input type="text"/> .0	75	95	≈ 1,21	≈ 1,44
220.087..... <input type="text"/> .0	87	107	≈ 1,27	–
220/760.100.. <input type="text"/> .0	100	120	≈ 1,32	≈ 1,64
220/760.125.. <input type="text"/> .0	125	145	≈ 1,43	≈ 1,84
220/760.150.. <input type="text"/> .0	150	170	≈ 1,54	≈ 2,02
220/760.175.. <input type="text"/> .0	175	195	≈ 1,65	≈ 2,26
220/760.200.. <input type="text"/> .0	200	220	≈ 1,76	≈ 2,40
220/760.225.. <input type="text"/> .0	225	245	≈ 1,87	≈ 2,56
220/760.250.. <input type="text"/> .0	250	270	≈ 1,98	≈ 2,85
220.275..... <input type="text"/> .0	275	295	≈ 2,09	–
220/760.300.. <input type="text"/> .0	300	320	≈ 2,20	≈ 3,21

Hot Chips up to 850°C

e-tubes that repel hot chips, up to 850°C. Some applications, depending on amount and size of the chips, can burn or melt the surface. That is no longer the case with the igus® "igumid HT" material. Order example: Full e-tube made of HT*: **760.050.150.0.HT**
Lids made of HT: **760.050.HTE.150.0**
*for long travels upon request
Further Information: www.igus.de/en/HT
Delivery time up to 4 weeks!

System E4/00
Inner height: 28 mm

Phone +49- (0) 22 03-96 49-800
Fax +49- (0) 22 03-96 49-222

Available bending radii

R [mm] 055* 063* 075 100 125 150 175 200 250

Supplement Part No. with required radius. Example: 220.300.250.0

0 = standard color, other colors ► page 1.39 · Pitch = 46 mm/link - Links/m = 22

*not available for R760

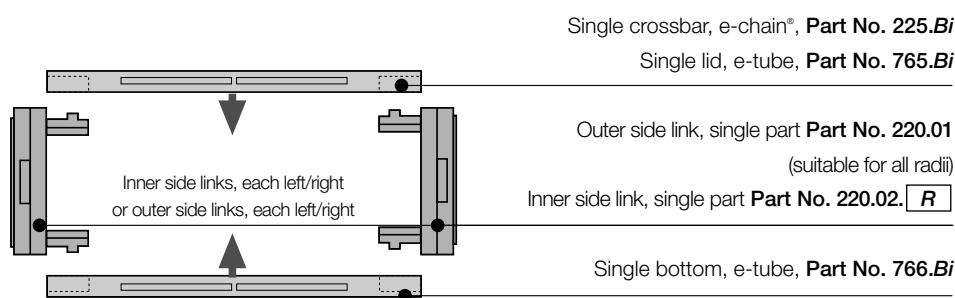

Part No. e-chain® links, single parts

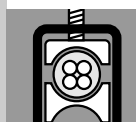
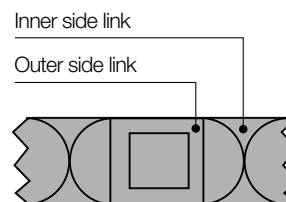

► page 7.255

igus® e-chainsystems®



Vertical separators are used if a vertical subdivision is required. In the standard configuration, a separator is mounted at every second link. **Note:** Observe a lateral spacing of at least 20 mm (e-tube)!

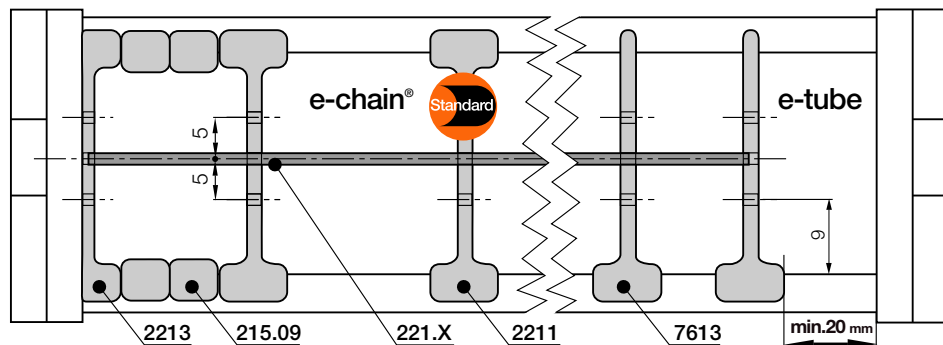

Phone +49- (0) 22 03-96 49-800
Fax +49- (0) 22 03-96 49-222



Vertical separator 2201



Vertical separator 7603



Spacer 205.09



Side plate 2203



Full-width shelf 220.X

Full-width shelf

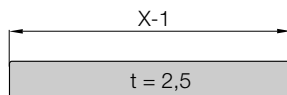

Vertical separator for e-chains®	
unassembled	2201
assembled	2211

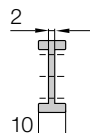

Vertical separator for e-tubes	
unassembled	7603
assembled	7613

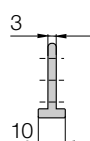

Spacer* for e-chains®	
unassembled	205.09
assembled	215.09



Side plate for e-chains®	
unassembled	2203
assembled	2213

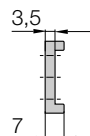

*For side-mounted applications

Option 1: Vertical separators and spacers

● **Standard separator 2201 for e-chains®** is used when vertical and horizontal separation is required. Due to its slot, it allows basic vertical/horizontal shelving arrangements.

● **Vertical separator 7603** for e-tubes R760.

● Separators (e.g. "side mounted") for e-chains® can be fixed in their position with **spacers 205.09**. The available inner height will be reduced by 2 mm, per spacer and side. To avoid this, the parts can be assembled on outside of the crossbar (not for long travels)

Additionally:

● **Side plate 2203 and full-width shelf 220.X** - this option makes sense in applications with many thin cables with similar diameters. It is based upon **vertical separator 2201 (7603)** for the Series **R760 e-tube** is put in place and the shelf is inserted into the separator's slots. If no separators are desired, **side plate 2203** must be used with the **Series 220 e-chain®**. This solution is not available for e-tubes.

Width X [mm]	Part No. unassembled	Part No. assembled
040	220.40	221.40
050	220.50	221.50
062	220.62	221.62
070	220.70	221.70
075	220.75	221.75
087	220.87	221.87

Width X [mm]	Part No. unassembled	Part No. assembled
100	220.100	221.100
125	220.125	221.125
150	220.150	221.150
175	220.175	221.175
200	220.200	221.200

igus® GmbH
51147 Cologne

Internet: www.igus.eu
E-mail: info@igus.de

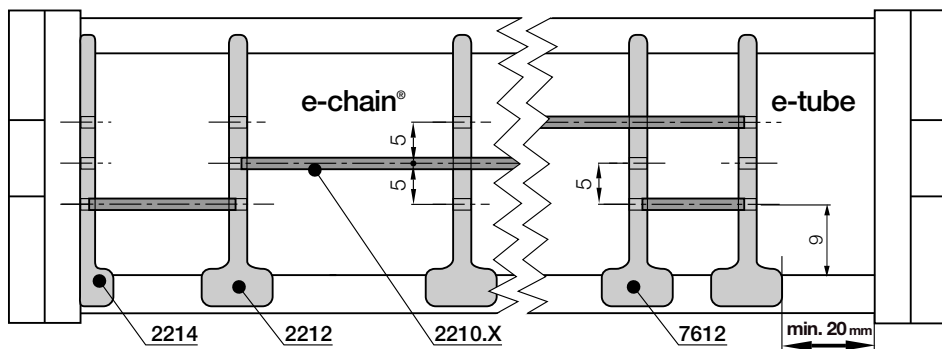

For use with many cables of differing diameters. e-chains® and e-tubes can be subdivided both vertically and horizontally. The shelves can be arranged elevator-shifted with different bottoms

Option 2: Shelves

● Side plates 2204, middle plates 2202 and shelves 2200.X form the basic pattern of a shelf system. Shelves of various widths can be arranged at 3 different heights (in 5 mm increments).

● A middle plate 7602 is available for the e-tube. Side plates are not available for the e-tube.

	Side plate for e-chains®	
	unassembled	2204
	assembled	2214

	Middle plate for e-chains®	
	unassembled	2202
	assembled	2212

	Middle plate for e-tubes	
	unassembled	7602
	assembled	7612



Side plate 2204



Middle plate 2202



Middle plate 7602



Shelf 2200.X

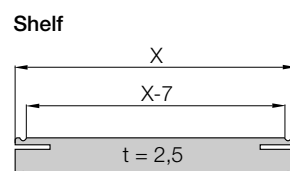

Shelf

Width X [mm]	Part No. unassembled	Part No. assembled
018	2200.18	2210.18
023	2200.23	2210.23
028	2200.28	2210.28
033	2200.33	2210.33
038	2200.38	2210.38
043	2200.43	2210.43
048	2200.48	2210.48

Width X [mm]	Part No. unassembled	Part No. assembled
058	2200.58	2210.58
068	2200.68	2210.68
073	2200.73	2210.73
088	2200.88	2210.88
099	2200.99	2210.99
124	2200.124	2210.124
149	2200.149	2210.149

System E4/00
Inner height: 28 mm

Phone +49- (0) 22 03-96 49-800
Fax +49- (0) 22 03-96 49-222

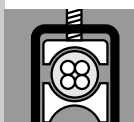
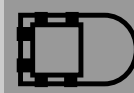

► page 7.255

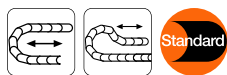

The Standard - Option KMA* - pivoting

- Recommended for unsupported and gliding applications
- Universally mountable with attachment capability on all sides
- Bolted connection outside of chain cross-section
- Confined installation conditions
- Corrosion resistant

*KMA = Polymer Metal Mounting Bracket

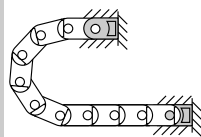

The attachment variants arising automatically by the choice of the KMA mounting bracket

Moving end
2200/7600...□.2

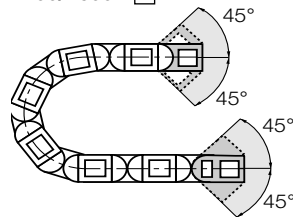

Fixed end
2200/7600...□.1

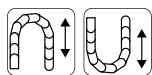

Option KMA - locking

- Recommended for vertical hanging / standing applications

Additionally:

- Universally mountable
- Corrosion resistant
- Locked connections
- At very high acceleration

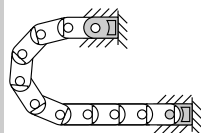

The attachment variants arising automatically by the choice of the KMA mounting bracket

Moving end
2300/7650...□.2

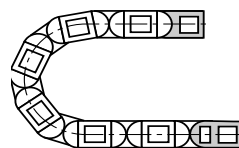

Fixed end
2300/7650...□.1

Dimensions and order configurations

Part No. structure (pivoting)

2200.	050.	2.	12
7600.			

Full set
odd/even
Width
2200 = e-chain*
7600 = e-tube

Part No. structure (locking)

2300.	050.	2.	12
7650.			

Full set
odd/even
Width
2300 = e-chain*
7650 = e-tube

Fixed end
2200/7600...□.1 (pivoting)
2300/7650...□.1 (locking)
Moving end
(pivoting) 2200/7600...□.2
(locking) 2300/7650...□.2

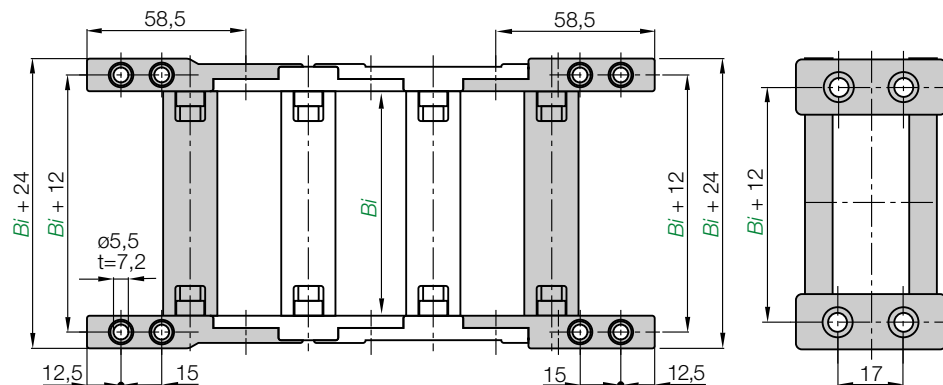

Width index	Part No. full set			Bi [mm]	Width index	Part No. full set			Bi [mm]
	pivoting	locking				pivoting	locking		
.040.	2200	2300	.040.□.12	40	.150.	2200/7600	2300/7650	.150.□.12	150
.050.	2200/7600	2300/7650	.050.□.12	50	.175.	2200/7600	2300/7650	.175.□.12	175
.062.	2200	2300	.062.□.12	62	.200.	2200/7600	2300/7650	.200.□.12	200
.070.	2200	2300	.070.□.12	70	.225.	2200/7600	2300/7650	.225.□.12	225
.075.	2200/7600	2300/7650	.075.□.12	75	.250.	2200/7600	2300/7650	.250.□.12	250
.087.	2200	2300	.087.□.12	87	.275.	2200	2300	.275.□.12	275
.100.	2200/7600	2300/7650	.100.□.12	100	.300.	2200/7600	2300/7650	.300.□.12	300
.125.	2200/7600	2300/7650	.125.□.12	125					

Please insert **1** for odd number of links or **2** for even number of links

Note: The E4/00 System may end with either an inner side or an outer side link. Keep in mind that an outer side link always forms the first chain link at the moving end. The Part No. depends on an even or odd numbers of links. Please insert: **1** for odd number of links or **2** for even number of links

Full set, for both ends:

2200.040. 2. 12 (even)

Single-part order:

2200.040. 2. 2 (even)

Mounting bracket moving end

2200.040. 2. 1 (even)

Mounting bracket fixed end



E4/00 | Series 220 · R760 | Accessories | Strain Relief

Strain relief tie-wrap plate Part No. 2050.Z can be fixed on the last crossbar. **Details ▶ chapter 10**

Part. No.	Width [mm]	Number of teeth
2050.Z	60	6

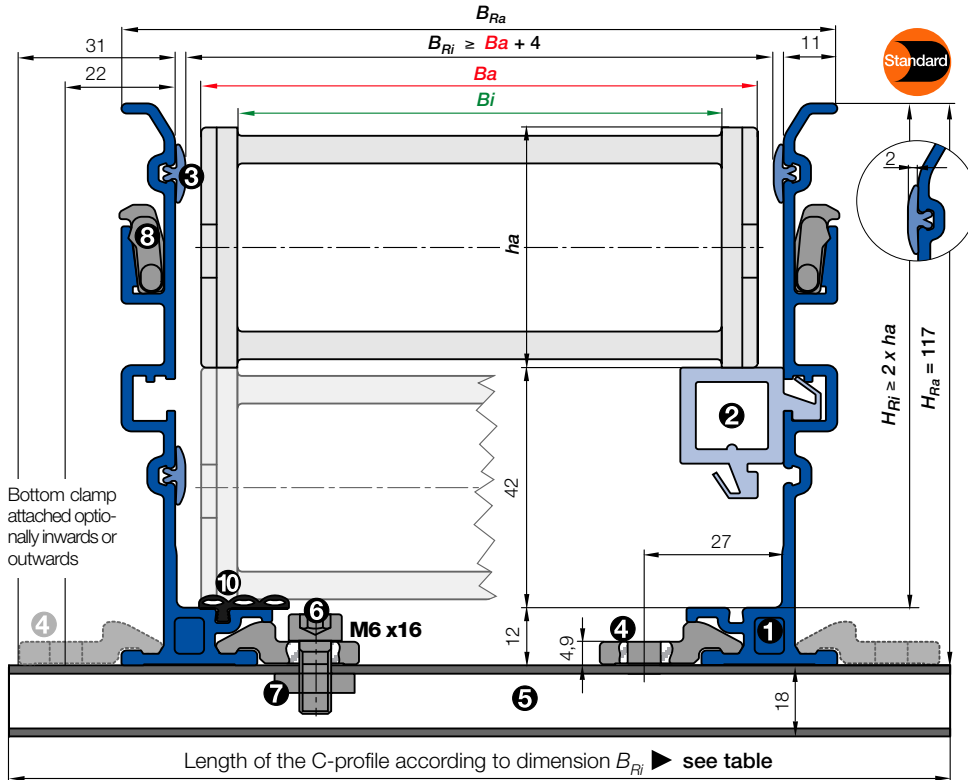

- **Components, trough "Basic":** ① Trough side parts, aluminum, 2 m ② Glide bar, plastic, 2 m ③ Glide strips, plastic, 2 m (without glide strips on request) ⑩ Optional: Silencer profile, rubber
- **Components, installation set "Basic":** ④ Bottom clamp, aluminum ⑤ C-profile, steel galvanized ⑥ Screw M6 x16 ⑦ Sliding nut M6 ⑧ Interface connector, plastic

- B_a = Outer width e-chains® / e-tube
- B_i = Inner width e-chains® / e-tube
- h_a = Outer height e-chains® / e-tube
- H_{Ri} = Inner trough height
- H_{Ra} = Outer trough height
- B_{Ri} = Inner trough width ▶ depends on dim. B_a
- B_{Ra} = Outer trough width
- n_{Mon} = Number of installation sets (left/right)
- n_{Ri} = Number of trough sets (left/right)
- ! $H_{Ri} \geq 2 \cdot h_a$
- ! $B_{Ri} \geq B_a + 4$
- = Guide trough set ● = Installation set "Basic"
- = Glide bar ● = C-profile

Installation set "Basic" with C-profile

Bottom Clamp attached optionally inwards or outwards

220.070.250.0 ▶ Order example

B_{Ri} [mm]	Part No. attached inwards	Part No. attached outwards	Part No.	
			attached inwards	attached outwards
.040	64	-	960.30.175	960.30.175
.050	74	960.30.125	960.30.175	960.30.175
.062	86	960.30.150	960.30.200	960.30.200
.070	94	960.30.150	960.30.200	960.30.200
.075	99	960.30.150	960.30.200	960.30.200
.087	111	960.30.175	960.30.225	960.30.225
.100	124	960.30.175	960.30.225	960.30.225
.125	149	960.30.200	960.30.250	960.30.250
.150	174	960.30.225	960.30.275	960.30.275
.175	199	960.30.250	960.30.300	960.30.300
.200	224	960.30.275	960.30.325	960.30.325
.225	249	960.30.300	960.30.350	960.30.350
.250	274	960.30.325	960.30.375	960.30.375
.275	299	960.30.350	960.30.400	960.30.400
.300	324	960.30.375	960.30.425	960.30.425

Order example: Length of travel 30 m - Center mounted for Series 220.070.250.0 with $B_{Ri} = 94$

Guide trough set (set of 2 trough side parts, incl. glide strips) **without** glide bar

Order text: 16 m guide trough without glide bar (8 x 2 m sections) Part No. 972.02.30.SL

Guide trough set (set of 2 trough side parts, incl. glide strips) **with** glide bar

Order text: 16 m guide trough with glide bar (8 x 2 m sections) Part No. 972.02.31.SL

Installation set "Basic" complete (guide trough-sets + 1)

Order text: 17 installation sets "Basic" Part No. 960.30.150

Module for the fixed end

Order text: 1 set Part No. 972.82

Option: For an additional noise dampening with silencer profile, please add Index A - Example:

Part No. 972.02.30.SLA

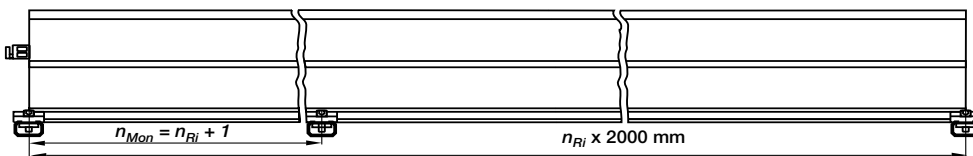

Principle sketch: Number of installation sets to be installed = **Number of trough sections + 1**



A quick fix for mounting the stationary end of an e-chain®

With this module for the fixed end, fast and easy mounting onto the Aluminum "SuperTrough" is now possible without any drilling. Fast mounting of the e-chain® by clamping onto the aluminum trough

- Quick relocation of the stationary end
- No drilling necessary

Insert for the installation set "Heavy-Duty": **972.50.XXX** instead of (**960.30.XXX**) on the right column "attached outwards"

Phone +49- (0) 22 03-96 49-800
 Fax +49- (0) 22 03-96 49-222

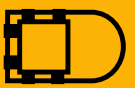

▶ chapter 10



▶ chapter 9



▶ page 7.255