

drylin® R liners | Product range

Short, closed design for round shafts –
made from iglidur® J (all-rounder)



Order key

Type Size

J U M-02-10

igidur® J	Liner	Metric	Compact	d1
-----------	-------	--------	---------	----

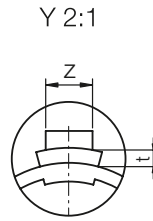
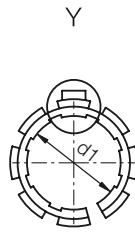
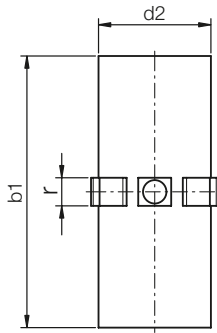

● Available also as low-clearance version (JUM-12...)



⁷⁸⁾ According to igus® testing method ► Page 1000

Please note: installation instructions ► Page 945



min. -50 °C

max. +90 °C

Dimensions [mm]

d1	d1-Tolerance ⁷⁸⁾	d2	b1	r	t	Z	Weight [g]	Part No.
10	+0.030 +0.070	12	25	3.0	0.8	2.5	1.02	JUM-02-10
12	+0.030 +0.070	14	27	3.0	0.8	3.0	1.27	JUM-02-12
16	+0.030 +0.070	18	29	3.5	0.8	3.5	1.82	JUM-02-16
20	+0.030 +0.070	23	29	5.0	0.8	3.5	3.27	JUM-02-20
25	+0.030 +0.070	28	39	5.0	0.8	4.0	5.75	JUM-02-25
30	+0.040 +0.085	34	49	5.0	0.8	4.0	11.28	JUM-02-30
40	+0.040 +0.085	44	59	6.0	1.3	5.0	17.94	JUM-02-40
45	+0.040 +0.085	50	59	7.0	1.3	6.0	27.00	JUM-02-45
50	+0.050 +0.150	55	69	7.0	1.3	6.0	32.56	JUM-02-50

Housing bore for liner JUM-02 | dimensions [mm]

Shaft Ø	d _i H7	B h10	r +0.05	t +0.1	f +0.5	Z +0.2	Part No.
10	12	26	3.0	1.0	1.0	2.6	JUM-02-10
12	14	28	3.0	1.0	1.5	3.1	JUM-02-12
16	18	30	3.5	1.0	1.7	3.6	JUM-02-16
20	23	30	5.0	1.0	2.0	3.6	JUM-02-20
25	28	40	5.0	1.0	2.0	4.1	JUM-02-25
30	34	50	5.0	1.0	2.0	4.1	JUM-02-30
40	44	60	6.0	1.5	2.5	5.1	JUM-02-40
45	50	60	7.0	1.5	2.5	6.1	JUM-02-45
50	55	70	7.0	1.5	2.5	6.1	JUM-02-50

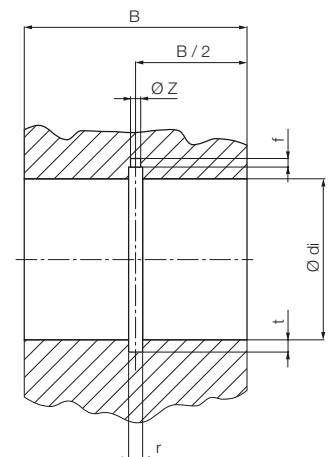

Can be combined with:



RJUM-02



RJUM-05/RJUME-05
TJUM-05/RJUMT-05



FJUMT-01/-02