

drylin® R liners | Product range

Long, open design for supported shafts –
made from iglidur® J (all-rounder)



Order key

Type	Size
J U M O-01-10	
igidur® J	d1
Liner	
Metric	
Open	
Standard	

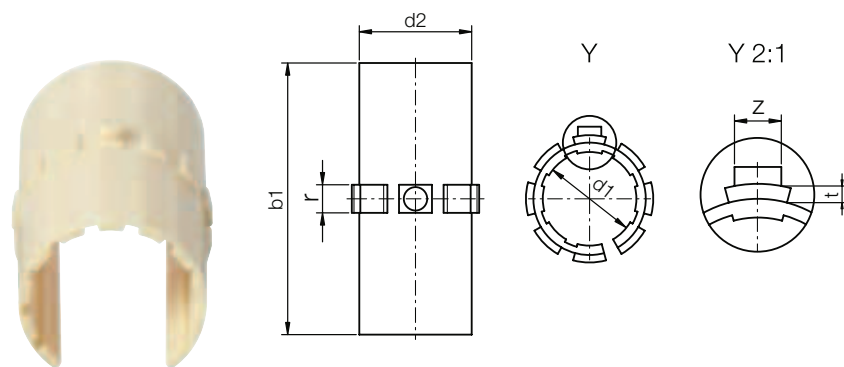

Inch Imperial dimensions
▶ Page 1400

i ⁷⁸⁾ According to igus® testing method ▶ Page 1000
Please note: installation instructions ▶ Page 945
t min. -50 °C
max. +90 °C

Dimensions [mm]

d1	d1-Tolerance ⁷⁸⁾	d2	b1	r	t	Z	Weight [g]	Part No.
10	+0.030 +0.070	12	28	3.0	0.8	2.5	0.90	JUMO-01-10
12	+0.030 +0.070	14	31	3.0	0.8	3.0	1.16	JUMO-01-12
16	+0.030 +0.070	18	35	3.5	0.8	3.5	1.71	JUMO-01-16
20	+0.030 +0.070	23	44	5.0	0.8	3.5	4.16	JUMO-01-20
25	+0.030 +0.070	28	57	5.0	0.8	4.0	6.97	JUMO-01-25
30	+0.040 +0.085	34	67	5.0	0.8	4.0	12.38	JUMO-01-30
40	+0.040 +0.085	44	79	6.0	1.3	5.0	20.18	JUMO-01-40
50	+0.050 +0.150	55	99	7.0	1.3	6.0	38.60	JUMO-01-50
60	+0.050 +0.150	65	124	8.0	2.5	6.5	60.10	JUMO-01-60⁷⁹⁾

Housing bore for liner JUMO-01 | dimensions [mm]

Shaft Ø	d1 H7	B h10	W	r +0.5	t +0.05	f +0.1	Z +0.2	Part No.
10	12	29	7.3	3.0	1.0	1.0	2.6	JUMO-01-10
12	14	32	9.0	3.0	1.0	1.5	3.1	JUMO-01-12
16	18	36	11.6	3.5	1.0	1.7	3.6	JUMO-01-16
20	23	45	12.0	5.0	1.0	2.0	3.6	JUMO-01-20
25	28	58	14.5	5.0	1.0	2.0	4.1	JUMO-01-25
30	34	68	16.6	5.0	1.0	2.0	4.1	JUMO-01-30
40	44	80	21.0	6.0	1.5	2.5	5.1	JUMO-01-40
50	55	100	25.5	7.0	1.5	2.5	6.1	JUMO-01-50
60	65	125	27.2	8.0	2.5	3.0	6.5	JUMO-01-60⁷⁹⁾

⁷⁹⁾ in two parts

Can be combined with:



OJUM-01/-03



OJUM-06/-06-LL

