

drylin® R quad blocks | Product range

Open, long design



Order key



Type	Option	Size
------	--------	------

O G A - 01 - 12

Linear housing with OJUM bearings	Aluminium housing	Standard with OJUM-01	Inner Ø
-----------------------------------	-------------------	------------------------------	---------

Options:

01: Standard with OJUM-01

03: With OJUM-03



Please note:
Installation instructions
▶ Page 945

● Housing: aluminium, equipped with drylin® R linear bearings

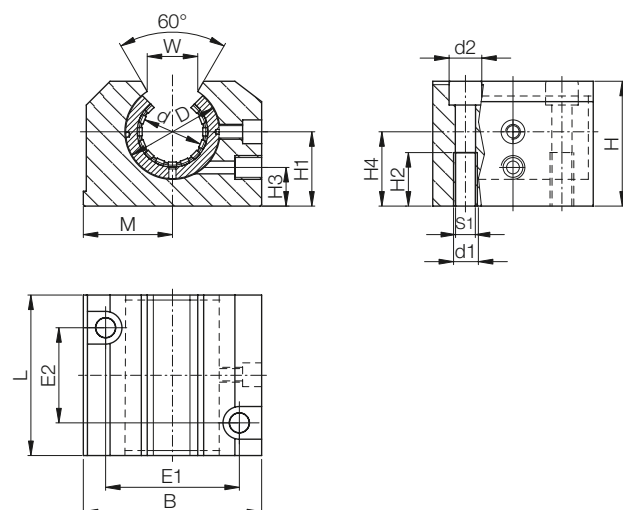

Dimensions [mm]

d	D	H	H1	H2	H3	H4	S1	B	L	M	E1	E2	d1	d2	W	Part No.	Self-aligning
	H6		+0.01 -0.02						±0.3	±0.02	±0.15	±0.15			+0.6	Standard with OJUM-01	Self-aligning with OJUM-03
12	22	28	18	11	8	25	M5	43	39	21.5	32	23	4.2	8	14	OGA-01-12	OGA-03-12
16	26	35	22	13	12	30	M6	53	43	26.5	40	26	5.2	10	17	OGA-01-16	OGA-03-16
20	32	42	25	18	13	34	M8	60	54	30.0	45	32	6.8	11	17	OGA-01-20	OGA-03-20
25	40	51	30	22	15	40	M10	78	67	39.0	60	40	8.6	15	21	OGA-01-25	OGA-03-25
30	47	60	35	22	16	48	M10	87	79	43.5	68	45	8.6	15	21	OGA-01-30	OGA-03-30
40	62	77	45	26	20	60	M12	108	91	54.0	86	58	10.3	18	27	OGA-01-40	OGA-03-40

Are equipped with:



OJUM-01



OJUM-03

Available with drylin® liners (optional: J200/A180):



J



E7



X