



Price index



Extremely low noise  
Test results upon request



IPA certificate: Class 1, according to  
standard DIN EN ISO 14644-1 for the  
E6 system (Series E6.29.060.150.0.CR,  
 $v = 0.5 \text{ m/s}$ ,  $a = 1.0 \text{ m/s}^2$ )



LEVEL 1 absorption confirmed by IPA-  
Fraunhofer-Institut according to SEMI  
E78-0998 for the E6 standard material



Lever and remove lids



## When to use the Series R6.52:

- Protection against dirt and chips
- If a low-noise version is required
- At very high speeds and/or accelerations
- For enlarged thrusts and tensile forces
- For small bending radii
- If less vibration is required
- Minimal abrasion  
(e.g. cleanroom applications)



## When not to use it:

- Limited in side-mounted applications  
▶ Series R4.42 System E4.1, page 7.60

- 1 No pin and bore connection
- 2 Can be shortened or lengthened due to modular design
- 3 Small pitch for low-noise, smooth operation
- 4 Continuous glide surfaces
- 5 Smooth, cable-protecting inner chamber
- 6 Interior stop dog
- 7 Very large gliding surfaces
- 8 Enclosed design protects from light debris, weld splatter and compromising environmental influences
- 9 KMA-Mounting Brackets with attachment points on all sides
- 10 Optional with or without integrated C-profile



## Order example complete e-chain®

Please indicate chain-lengths or number of links **Example: 2 m or 68 links**2 m **R6.52.100.075.0**

e-tube

with 2 separators **R6.52.11** assembled every 2<sup>nd</sup> link

Interior separation

1 set **R6.520.100.12**

Mounting bracket



**Unsupported length**

$FL_G$  = with straight upper run  
 $FL_B$  = with permitted sag  
 Further information ► **Design, page 1.12**

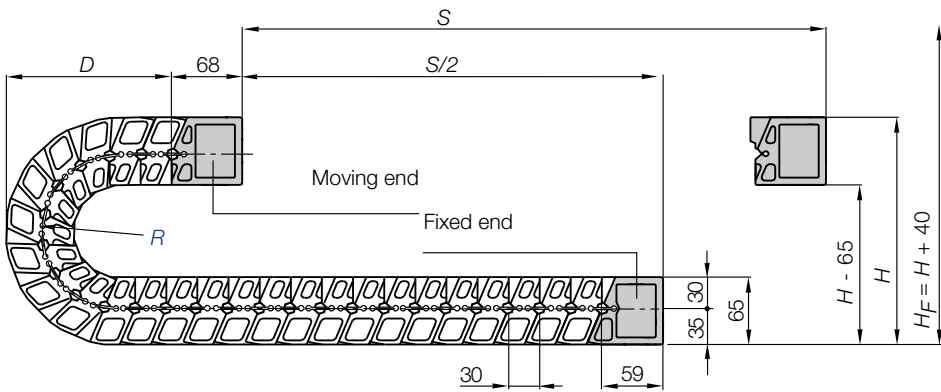
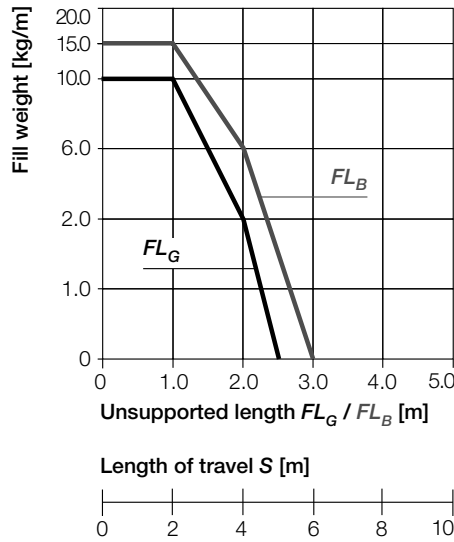
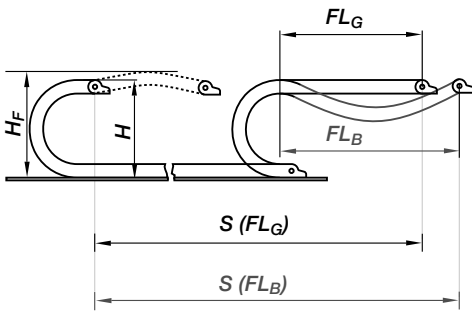

Pitch = 30 mm/link Links/m = 34 (1020 mm) Chain length =  $S/2 + K$

<b>R</b>	<b>075</b>	<b>100</b>	<b>150</b>	<b>200</b>	<b>250</b>
<b>H</b>	270	320	420	520	620
<b>D</b>	140	165	215	265	315
<b>K</b>	300	375	535	690	850
<b>H<sub>2</sub></b>	140	140	140	140	140
<b>D<sub>2</sub><sup>+25</sup></b>	270	398	768	1138	1508
<b>K<sub>2</sub></b>	300	480	990	1470	1950

If you intend to use this series on long travels, we request you to consult us!

Long travel lengths from 6 m to max. 80 m Chain length =  $S/2 + K_2$

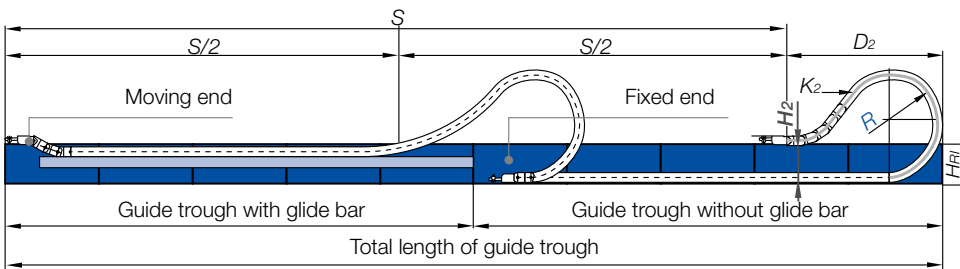

In case of travels between 4 m and 6 m we recommend a longer unsupported length.

- $S$  = Length of travel
  - $R$  = Bending radius
  - $H$  = Nominal clearance height
  - $H_F$  = Required clearance height
  - $H_{RI}$  = Trough inner height
  - $D$  = Overlength e-chain® radius in final position
  - $K = \pi \cdot R + \text{"safety"}$
  - $D_2$  = Over length - long travels, gliding
  - $K_2 = \text{"Further add-on"}$
  - $H_2 = \text{"Mounting height"}$
- \*if the mounting bracket location is set lower

**Other installation methods**

- Vertical, hanging  $\leq 50$  m
- Vertical, standing  $\leq 2$  m
- Side mounted, unsupported = possible to a limited extent
- Unsupported length of upper run = upon request

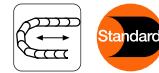

**Short travels - unsupported**

Unsupported e-chains® feature positive camber over short travels. This must be accounted for when specifying the clearance height  $H_F$ . Please consult igus® if space is particularly restricted.

The required clearance height:  
 $H_F = H + 40$  mm  
 (with 2,0 kg/m fill weight)



**Gliding, long travel applications (max. 80 m)**

In this case the e-chain® upper run will be introduced in a guide trough on the lower run. We recommend to realize the engineering of such a plant by our technicians.

**Technical Data**

Speed / acceleration $FL_G$	max. 20 [m/s] / max. 200 [m/s <sup>2</sup> ]
Speed / acceleration $FL_B$	max. 3 [m/s] / max. 6 [m/s <sup>2</sup> ]
Gliding speed / acceleration (maximum)	upon request
permitted temperature °C	-40° up to +70° C
Flammability class	VDE 0304 IIC UL94 HB



Details of material properties

► page 1.38

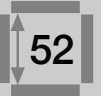

System E6  
 Inner height: 52 mm

Phone +49- (0) 22 03-96 49-800  
 Fax +49- (0) 22 03-96 49-222

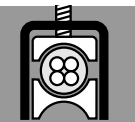

► page 8.39

For support of the lower run - **Support Tray tool kit** available ► page 9.70

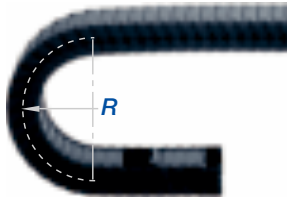
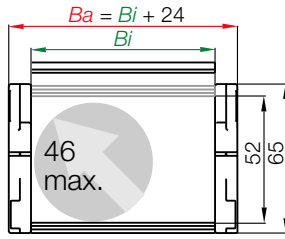

Serie R6.52 e-tube, lids can be removed along inner and outer radius

Part No.	Bi [mm]	Ba [mm]	R [mm]	Bending radii				Weight [kg/m]
R6.52.040.□.0	40	64	075	100	150	200	250	≈ 1,78
R6.52.050.□.0	50	74	075	100	150	200	250	≈ 1,89
R6.52.062.□.0	62	86	075	100	150	200	250	≈ 1,97
R6.52.070.□.0	70	94	075	100	150	200	250	≈ 2,07
R6.52.075.□.0	75	99	075	100	150	200	250	≈ 2,12
R6.52.087.□.0	87	111	075	100	150	200	250	≈ 2,21
R6.52.100.□.0	100	124	075	100	150	200	250	≈ 2,35
R6.52.125.□.0	125	149	075	100	150	200	250	≈ 2,57
R6.52.150.□.0	150	174	075	100	150	200	250	≈ 2,80
R6.52.175.□.0	175	199	075	100	150	200	250	≈ 3,03
R6.52.200.□.0	200	224	075	100	150	200	250	≈ 3,25
R6.52.225.□.0	225	249	075	100	150	200	250	≈ 3,46
R6.52.250.□.0	250	274	075	100	150	200	250	≈ 3,68
R6.52.275.□.0	275	299	075	100	150	200	250	≈ 3,92
R6.52.300.□.0	300	324	075	100	150	200	250	≈ 4,15

The widths 040 / 062 / 062 / 070 / 200 / 225 / 250 / 275 / 300 are available upon request.

Time of delivery approx. 6-8 weeks after order.

Supplement Part No. with required radius. Example: R6.52.100.075.0

0 = standard color, other colors ▶ page 1.39 · Pitch = 30 mm/link - Links/m = 34



Part No. structure

R6.52.100.075.0



E6 | e-tube | Series R6.52 | Accessories | Interior Separation

Trennsteg

unassembled R6.52.01

assembled R6.52.11

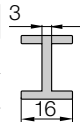

Option 1: Vertical separators

Vertical separators are used if a vertical subdivision of the e-chain® interior is required - By standard vertical separators are assembled every other e-chain® link!

- The notches on this separator marks the sticking side for a stuck mounting on the lid
- Standard subdivision with vertical separator R6.52.11



Separator, R6.52.01 (side view)

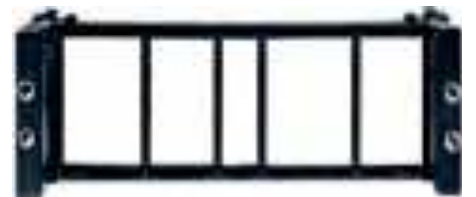
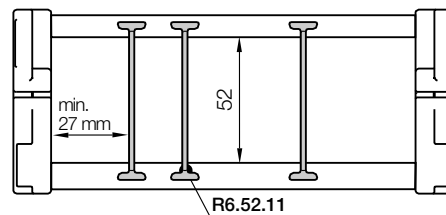

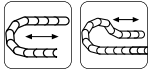

\* KMA = Polymer Metal Mounting Bracket

Moving end  
R6.520...2

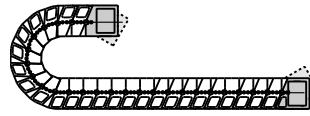

**Option KMA\* - pivoting**

- Option - integrated C-profile strain relief device with chainfix clip or strain relief tiwrap plates
- C-profile mountable in the inner or outer radius of the e-chain\*
- Bolted connection outside of chain cross-section
- Recommended for unsupported and gliding applications
- Confined installation conditions
- Universal mountable with attachment capability on all sides

R6.520...1  
Fixed end

The attachment variants arising automatically by the choice of the KMA mounting bracket

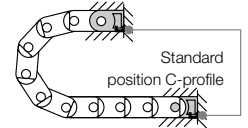

R6.520...2  
Fixed end

R6.520...1  
Moving end

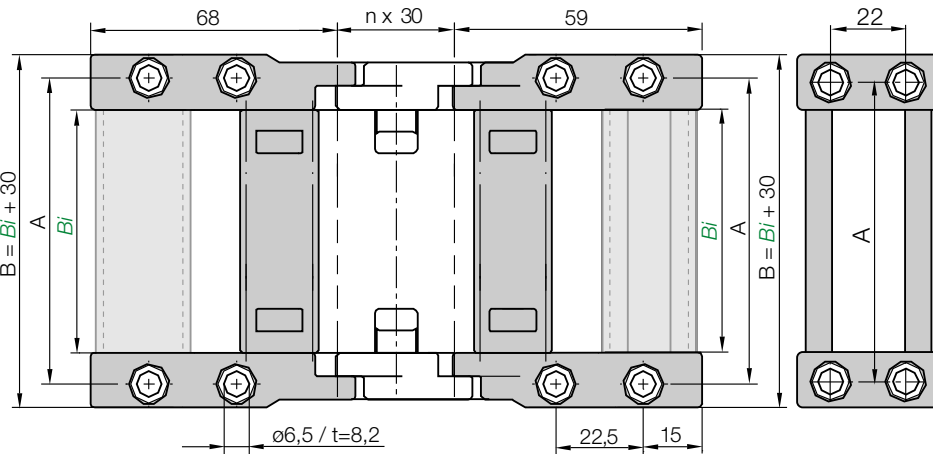

**Dimensions and order configurations**

For e-chain*	Part No. full set optional with C-profile	Dim. A [mm]	Dim. B [mm]
R6.52.040.	R6.520.040.12.C	56	70
R6.52.050.	R6.520.050.12.C	66	80
R6.52.062.	R6.520.062.12.C	78	92
R6.52.070.	R6.520.070.12.C	86	100
R6.52.075.	R6.520.075.12.C	91	105
R6.52.087.	R6.520.087.12.C	103	117
R6.52.100.	R6.520.100.12.C	116	130
R6.52.125.	R6.520.125.12.C	141	155

For e-chain*	Part No. full set optional with C-profile	Dim. A [mm]	Dim. B [mm]
R6.52.150.	R6.520.150.12.C	166	180
R6.52.175.	R6.520.175.12.C	191	205
R6.52.200.	R6.520.200.12.C	216	230
R6.52.225.	R6.520.225.12.C	241	255
R6.52.250.	R6.520.250.12.C	266	280
R6.52.275.	R6.520.275.12.C	291	300
R6.52.300.	R6.520.300.12.C	316	330

Part No. structure

R6.520.050.12.C

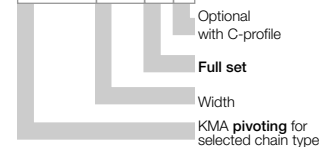

Full set, for both ends:

R6.520.050.12.C (with C-profile)

Single-part order:

R6.520.050.1.C (with C-profile)

Fixed end mounting bracket

R6.520.050.2.C (with C-profile)

Moving end mounting bracket

Phone +49- (0) 22 03-96 49-800  
Fax +49- (0) 22 03-96 49-222

**E6 | e-tube | Series R6.52 | Accessories | Strain Relief**

Strain relief tiwrap plate can be fixed on the last crossbar, alternatively with C-profile. Tiwrap plate as individual part - Part No. 30XX.ZB. Further strain relief elements ► chapter 10



Other strain relief elements - optional ► chapter 10

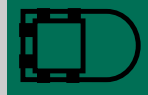

Chapter 10



Trough E6.52 ► page 8.71



► page 8.39



Aluminum "SuperTrough" for Series R6.52 ► page 8.71