



Order key

Type

Size

**W A C - 06**

Shaft end block

Compact version

Inner Ø

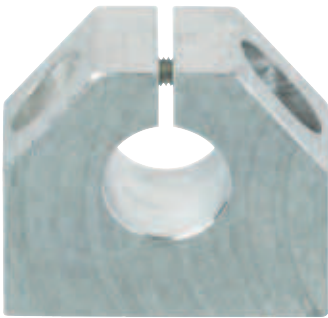

Material: Aluminium

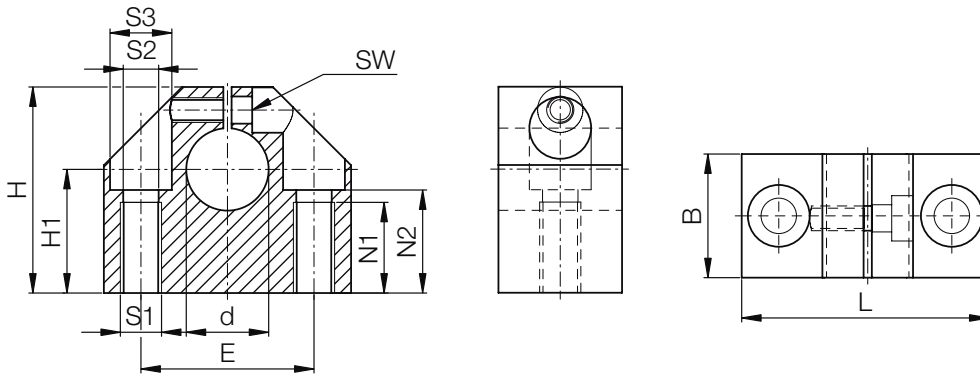

### Dimensions [mm]

Part No.	d	B	H	H1 <small>+0.01 up to +0.02</small>	L	S1	S2	S3	E <small>±0.1</small>	N1	N2	SW	Weight [g]
WAC-06	6	16	27	15	32	M5	4.2	8	22	11	13	2.5	30
WAC-08	8	16	27	16	32	M5	4.2	8	22	11	13	2.5	30
WAC-10	10	18	33	18	40	M6	5.2	10	27	13	16	3.0	50
WAC-12	12	18	33	19	40	M6	5.2	10	27	13	16	3.0	50
WAC-14	14	20	38	20	45	M6	5.2	10	32	13	18	3.0	70
WAC-16	16	20	38	22	45	M6	5.2	10	32	13	18	3.0	70
WAC-20	20	24	45	25	53	M8	6.8	11	39	18	22	4.0	120
WAC-25	25	28	54	31	62	M10	8.6	15	44	22	26	5.0	170
WAC-30	30	30	60	34	67	M10	8.6	15	49	22	29	5.0	220
WAC-40	40	40	76	42	87	M12	10.3	18	66	26	38	6.0	480
WAC-50	50	50	92	50	103	M16	14.25	20	80	34	46	8.0	820



Order example:

WAC-12: shaft end block, compact design with inner Ø 12 mm