

## Stehlager ESTM

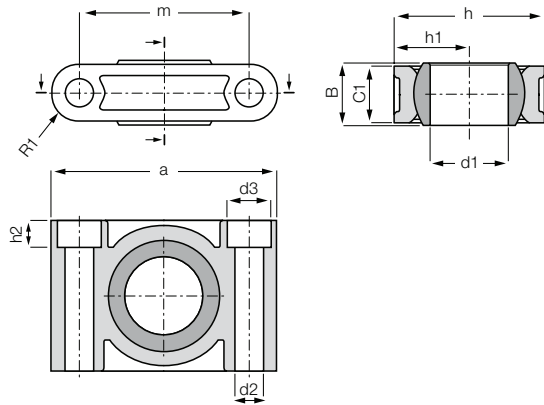

- Hohe radiale Belastung
- In Medien einsetzbar
- Platzsparend, einfach montierbar
- Lebensdauer berechenbar



## Bestellschlüssel

Typ

Größe [mm]

**E ST M -08**

Maßreihe E

Stehlager

metrisch

Innen-Ø



### Material:

Gehäuse: **igumid G** ▶ Seite 1433

Kalotte: **iglidur® W300** ▶ Seite 153

Kombination mit **xiros®-Kugellager** ▶ ab Seite 820

- Wartungs- und schmiermittelfrei
- Maßreihe E in Anlehnung an DIN ISO 12240
- Adapter erhältlich ▶ Zubehör, Seite 749

## Technische Daten

Art.-Nr.	max. radiale Zugkraft		max. radiale Druckkraft		max. axiale Kraft		max. Anzugsmom. in der Befestigung [Nm]	Gewicht [g]
	kurzzeitig [N]	langzeitig [N]	kurzzeitig [N]	langzeitig [N]	kurzzeitig [N]	langzeitig [N]		
ESTM-08	2.500	1.250	4.300	2.150	600	300	1,3	5
ESTM-10	3.400	1.700	5.300	2.650	700	350	2,5	7,1
ESTM-12	4.500	2.250	6.500	3.250	750	375	2,5	9
ESTM-16	6.700	3.350	8.500	4.250	1.100	550	4,5	17,5
ESTM-20	8.500	4.250	11.000	5.750	1.400	700	4,5	27,4
ESTM-25	13.500	6.750	18.500	9.250	2.300	1.150	10,5	50,8
ESTM-30 <sup>25)</sup>	10.000	5.000	16.500	8.250	2.500	1.250	10,5	79,7

<sup>25)</sup> Abnehmende Festigkeitswerte aufgrund unterschiedlicher Angusskonzepte

## Abmessungen [mm]

Art.-Nr.	d1, E10	d2	d3	h	h1	h2	a	m	C1	B	R1	max. Kippwinkel
ESTM-08	8,0	4,5	–	19	9,5	–	31,0	22,0	9,0	8,0	4,5	22°
ESTM-10	10,0	5,5	–	22	11	–	36,0	26,0	10,0	9,0	5,0	22°
ESTM-12	12,0	5,5	–	26	13	–	38,0	28,0	10,0	10,0	5,0	22°
ESTM-16	16,0	6,6	10,6	34,0	17,0	6,4	50,0	37,0	13,0	13,0	6,5	22°
ESTM-20	20,0	9,0	14,0	40,0	20,0	8,6	62,0	46,0	16,0	16,0	8,0	22°
ESTM-25	25,0	9,0	14,0	48,0	24,0	8,6	72,0	54,0	18,0	20,0	9,0	20°
ESTM-30	30,0	11,0	17,0	56,0	28,0	10,6	86,0	64,0	22,0	22,0	11,0	20°

## Alternative Kalottenwerkstoffe ▶ Seite 731



J4VEM:  
spielfrei  
vorgespannt



JEM: geringe  
Feuchtigkeits-  
aufnahme



REM:  
low-cost



J4EM:  
low-cost, geringe  
Feuchtigkeitsaufnahme