



Tangential-flow full cone nozzles Series 422 / 423



Tangentially arranged liquid supply. Without swirl inserts. Non-clogging. Stable spray angle. Uniform spray.

Applications:

Cleaning and washing process, cooling of gaseous fluids and solids, surface spraying, spraying onto mats in air washers, improving on chemical reactions, continuous casting, foam control.

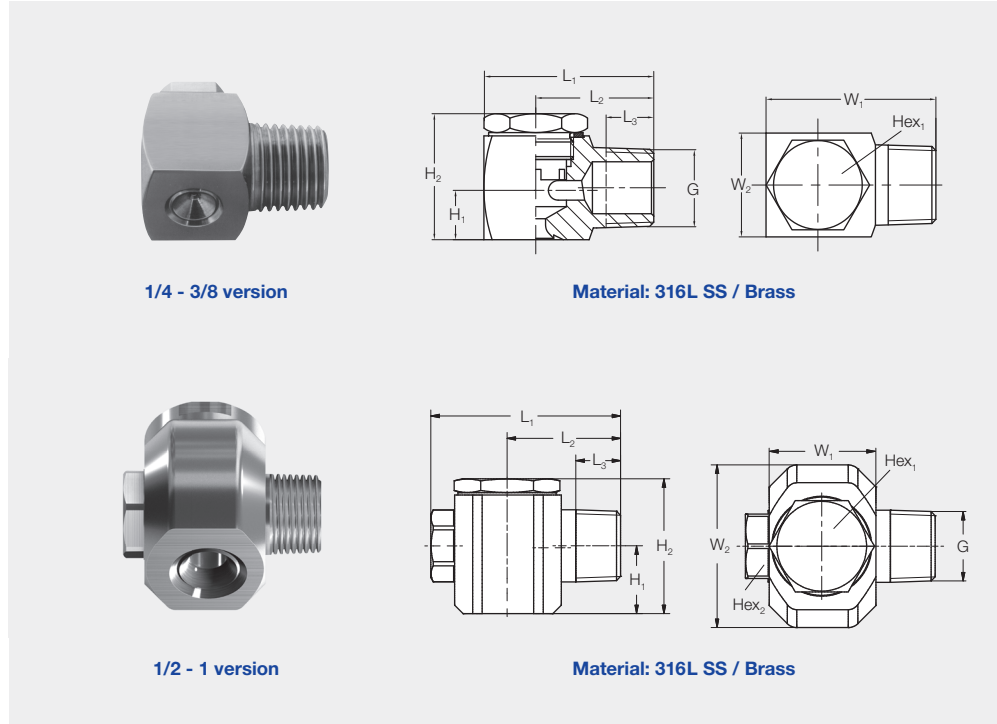

Dimensions [mm]										Weight 316L SS
G	L ₁	L ₂	L ₃	H ₁	H ₂	W ₁	W ₂	Hex ₁	Hex ₂	
1/4 BSPT	28.0	20.0	9.7	8.0	21.0	15.6	16.0	11	-	44 g
3/8 BSPT	36.0	25.0	10.1	11.0	26.7	23.2	22.0	19	-	101 g
1/2 BSPT	56.0	33.5	13.2	20.0	40.0	32.0	48.0	27	19	370 g
3/4 BSPT	65.5	38.5	14.5	23.5	57.0	40.0	63.0	36	27	830 g
1 BSPT	85.0	48.5	16.8	27.3	66.0	55.0	78.0	41	36	1581 g

Spray angle 	Ordering no.								B Ø [mm]	E Ø [mm]	V̇ [l/min]						Spray diameter D at p = 1-10 bar	
	Type	Mat. no.		Code				p [bar]						H = 200 mm	H = 500 mm			
		30 Brass	1Y 316L SS	1/4 BSPT	3/8 BSPT	1/2 BSPT	3/4 BSPT	1 BSPT			0.5	1.0	2.0			3.0	5.0	10.0
60°	422.644	○	○	-	CE	-	-	-	3.00	3.00	2.00	2.83	4.00	4.90	6.32	8.94	225	510
90°	422.406	○	○	CC	-	-	-	-	1.40	1.40	0.50	0.71	1.00	1.22	1.58	2.24	380	860
	422.486	-	○	CC	-	-	-	-	1.85	1.85	0.80	1.13	1.60	1.96	2.53	3.58	380	860
	422.566	○	○	CC	-	-	-	-	2.25	2.25	1.25	1.77	2.50	3.06	3.95	5.59	380	860
	422.606	○	○	-	CE	-	-	-	2.55	2.55	1.57	2.23	3.15	3.86	4.98	7.04	380	860
	422.646	○	○	-	CE	-	-	-	2.90	2.90	2.00	2.83	4.00	4.90	6.32	8.94	390	960
	422.726	○	-	-	CE	-	-	-	3.70	3.70	3.15	4.45	6.30	7.72	9.96	14.09	390	960
	422.766	-	○	-	CE	-	-	-	4.15	4.15	4.00	5.66	8.00	9.80	12.65	17.89	390	960
	422.806	○	-	-	CE	-	-	-	4.65	4.65	5.00	7.07	10.00	12.25	15.81	22.36	390	960
	422.846	○	○	-	CE	-	-	-	5.30	5.30	6.25	8.84	12.50	15.31	19.76	27.95	390	960
	422.886	○	○	-	CE	-	-	-	5.85	6.00	8.00	11.31	16.00	19.60	25.30	35.78	390	960
422.966	-	○	-	-	CG	-	-	8.00	8.00	12.50	17.68	25.00	30.62	39.53	55.90	390	960	

B = Bore diameter · E = Narrowest free cross section

Continued on next page.

Example Type + Material-no. + Code = Ordering no.
for ordering: 422.644 + 30 + CE = 422.644.30.CE







Tangential-flow full cone nozzles

Series 422 / 423



Spray angle 	Ordering no.								B Ø [mm]	E Ø [mm]	\dot{V} [l/min]						Spray diameter D at p = 1-10 bar 	
	Type	Mat.no.		Code							p [bar]						H = 200 mm	H = 500 mm
		30 Brass	1Y 316L SS	1/4 BSPT	3/8 BSPT	1/2 BSPT	3/4 BSPT	1 BSPT			0.5	1.0	2.0	3.0	5.0	10.0		
120°	422.488	○	-	CC	-	-	-	-	1.90	1.90	0.80	1.13	1.60	1.96	2.53	3.58	680	1220
	422.568	○	○	CC	-	-	-	-	2.45	2.40	1.25	1.77	2.50	3.06	3.95	5.59	680	1220
	422.608	○	-	-	CE	-	-	-	2.70	2.70	1.57	2.23	3.15	3.86	4.98	7.04	680	1600
	422.728	○	○	-	CE	-	-	-	4.00	3.90	3.15	4.45	6.30	7.72	9.96	14.09	680	1600
	422.808	-	○	-	CE	-	-	-	4.90	4.90	5.00	7.07	10.00	12.25	15.81	22.36	680	1600
	422.848	○	○	-	CE	-	-	-	5.30	5.30	6.25	8.84	12.50	15.31	19.76	27.95	680	1600
	422.888	○	○	-	CE	-	-	-	6.60	6.00	8.00	11.31	16.00	19.60	25.30	35.78	680	1600
	422.928	-	○	-	-	CG	-	-	7.30	7.30	10.00	14.14	20.00	24.49	31.62	44.72	680	1600
	422.968	○	○	-	-	CG	-	-	8.00	8.00	12.50	17.68	25.00	30.62	39.53	55.90	680	1600
	423.008	-	○	-	-	CG	-	-	8.70	8.70	15.75	22.27	31.50	38.88	49.81	70.44	680	1600
	423.128	-	○	-	-	-	-	CK	12.70	12.30	31.50	44.55	63.00	77.16	99.61	140.87	680	1600
	423.208	-	○	-	-	-	-	CM	17.00	16.00	50.00	70.71	100.00	122.47	158.11	223.61	680	1600

B = Bore diameter · E = Narrowest free cross section

Full cone nozzles

Example Type + Material-no. + Code = Ordering no.
for ordering: 422.488 + 30 + CC = 422.488.30.CC

Conversion formula for the above series: $\dot{V}_2 = \dot{V}_1 \cdot \sqrt{\frac{p_2}{p_1}}$