



High pressure flat fan nozzles Series 6FH



With spray stabilizer.
Sharp uniform flat fan with an extremely narrow jet depth.

Applications:

High pressure cleaning.

Materials:

Nozzle body:

303 SS

Insert:

hardened stainless steel

420F SS

Spray Stabilizer:

301 SS

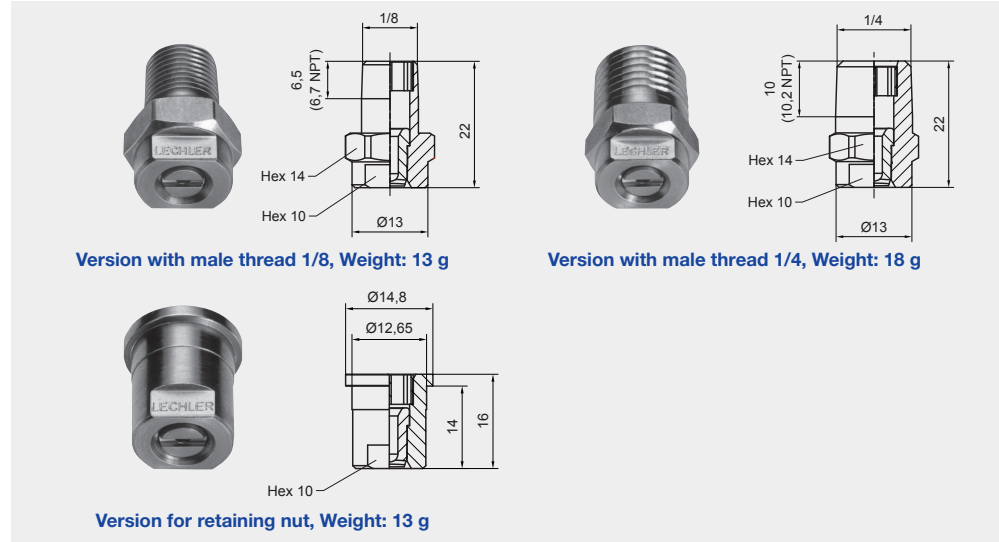

US gal/min. at 40 psi	Nozzle code	Flow rate code				Material no. A3	A Ø [mm]	\dot{V} [l/min]							
		Spray angle						p [bar]							
		20°	30°	45°	60°			40	60	80	100	120	150	200	
02	6FH	361	362	363	364	○	1.00	2.88	3.53	4.08	4.56	5.00	5.58	6.45	
021	6FH	371	372	373	374	○	1.02	3.03	3.71	4.28	4.79	5.25	5.87	6.77	
025	6FH	381	382	383	384	○	1.10	3.60	4.42	5.10	5.70	6.24	6.98	8.06	
028	6FH	391	392	393	394	○	1.16	4.04	4.94	5.71	6.38	6.99	7.81	9.02	
03	6FH	401	402	403	404	○	1.18	4.32	5.29	6.11	6.83	7.48	8.37	9.66	
034	6FH	411	412	413	414	○	1.30	4.90	6.00	6.93	7.75	8.49	9.49	10.96	
038	6FH	441	442	443	-	○	1.33	5.48	6.72	7.75	8.67	9.50	10.62	12.26	
04	6FH	451	452	453	454	○	1.35	5.77	7.06	8.16	9.12	9.99	11.17	12.90	
043	6FH	461	462	-	-	○	1.38	6.20	7.59	8.77	9.80	10.74	12.00	13.86	
045	6FH	471	472	473	474	○	1.40	6.49	7.95	9.18	10.26	11.24	12.57	14.51	
05	6FH	481	482	483	484	○	1.55	7.21	8.83	10.20	11.40	12.49	13.96	16.12	
055	6FH	501	502	503	504	○	1.60	7.93	9.71	11.22	12.54	13.74	15.36	17.73	
06	6FH	521	522	523	524	○	1.72	8.65	10.60	12.24	13.68	14.99	16.75	19.35	
065	6FH	531	532	533	534	○	1.75	9.37	11.48	13.26	14.82	16.23	18.15	20.96	
07	6FH	541	542	543	544	○	1.80	10.09	12.36	14.28	15.96	17.48	19.55	22.57	
075	6FH	551	552	553	554	○	1.90	10.81	13.25	15.29	17.10	18.73	20.94	24.18	
08	6FH	571	572	573	574	○	2.05	11.54	14.13	16.31	18.24	19.98	22.34	25.80	
087	6FH	581	582	583	584	○	2.06	12.54	15.36	17.74	19.83	21.72	24.29	28.04	
09	6FH	591	592	593	594	○	2.10	12.98	15.89	18.35	20.52	22.48	25.13	29.02	
10	6FH	601	602	603	604	○	2.30	14.41	17.65	20.38	22.79	24.97	27.91	32.23	
11	6FH	621	622	623	624	○	2.40	15.86	19.42	22.42	25.07	27.46	30.70	35.45	
125	6FH	641	642	643	644	○	2.50	18.02	22.07	25.48	28.49	31.21	34.89	40.29	
131	6FH	651	652	653	654	○	2.55	18.89	23.13	26.71	29.86	32.71	36.57	42.23	
139	6FH	661	662	663	664	○	2.65	20.04	24.54	28.34	31.68	34.70	38.80	44.80	
15	6FH	671	672	673	674	○	2.70	21.62	26.48	30.58	34.19	37.45	41.87	48.35	
175	6FH	701	702	703	704	○	3.00	25.23	30.90	35.68	39.89	43.70	48.86	56.41	
20	6FH	-	-	723	724	○	3.05	28.83	35.31	40.78	45.59	49.94	55.84	64.47	
25	6FH	-	-	763	764	○	3.50	36.04	44.14	50.97	56.99	62.43	69.80	80.60	
30	6FH	-	-	793	-	○	3.90	43.25	52.97	61.16	68.38	74.91	83.75	96.70	

A = Equivalent bore diameter

Connection code	Connection	p_{max}^* [bar]
CA	1/8 BSPT	approx. 700
BA	1/8 NPT	approx. 700
CC	1/4 BSPT	approx. 700
BC	1/4 NPT	approx. 700
29	Retaining nut	approx. 300

* Only valid for operation at constant pressure

Example for ordering:

Nozzle code + **Flow rate code** + **Material code** + **Connection code** = **Ordering no.**
6FH + **361** + **A3** + **CA** = **6FH.361.A3.CA**
 (Flat fan 20°; 4.52 l/min. at 100 bar; 1/8 BSPT)

