



Axial-flow full cone nozzles for retaining nut

Series 468



Full cone nozzle for assembly with retaining nut. Uniform full cone spray.

Applications:

Surface spraying, spraying over packings, chemical process engineering, cleaning and washing processes, cooling of gaseous fluids and solids.

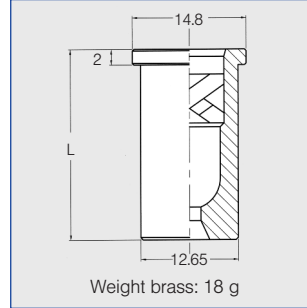

Spray angle	Ordering no.			B Ø [mm]	E Ø [mm]	V̇ [l/min]							L [mm]	Spray diameter D at p = 2 bar		
	Type	Mat.-no.				p [bar]								H = 200 mm	H = 500 mm	
		17 ¹⁾	30			5E	0.5	1.0	2.0	[US gal./min] at 40 psi	3.0	5.0				10.0
60°	468. 604	●	●	-	2.05	1.40	1.81	2.39	3.15	0.98	3.70	4.54	6.00	18	220	560
	468. 644	-	●	●	2.40	1.90	2.30	3.03	4.00	1.20	4.70	5.77	7.61	24.5	220	560
	468. 684	-	●	-	2.60	2.00	2.87	3.79	5.00	1.55	5.88	7.21	9.52	24.5	220	560
	468. 724	●	●	-	2.90	2.00	3.62	4.77	6.30	1.89	7.41	9.09	11.99	24.5	220	560
90°	468. 526	●	●	●	1.65	1.30	1.15	1.52	2.00	0.60	2.35	2.89	3.81	18	380	860
	468. 846	●	●	-	4.05	3.20	7.18	9.47	12.50	3.75	14.70	18.03	23.80	24.5	380	960
120°	468. 368	-	●	-	0.95	0.70	0.36	0.48	0.63	0.20	0.74	0.91	1.20	18	680	1540
	468. 408	●	●	-	1.20	0.85	0.57	0.76	1.00	0.30	1.18	1.44	1.90	18	680	1540
	468. 488	●	●	-	1.50	1.00	0.92	1.21	1.60	0.48	1.88	2.31	3.05	18	680	1540
	468. 528	●	●	-	1.65	1.20	1.15	1.52	2.00	0.60	2.35	2.89	3.81	18	680	1540

¹⁾ We reserve the right to deliver AISI 316Ti or AISI 316L under the material no. 17. B = bore diameter · E = narrowest free cross section

The folded page at the end of the catalogue will give you a survey on the various assembly possibilities. For complete assembly accessories, please refer to »Accessories«.

Example for ordering	Type	+	Material-no.	=	Ordering no.
	468. 604	+	17	=	468. 604. 17

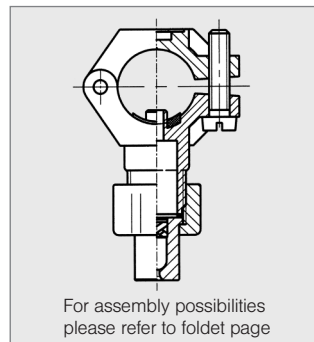

Conversion formula for the above series: $\dot{V}_2 = \dot{V}_1 * \left(\frac{p_2}{p_1}\right)^{0,4}$ (≤ 10 bar)

